

SPARE
PARTS
MANUAL
AUTOMATIC
DISPENSER

LUCE

X

SNAC

rheavendors 

ERSATZEIL-
HANDBUCH
SELBSTVERKÄUFER
AUTOMAT

HOW TO ORDER

To order spare parts always quote :

1°

The model and the serial number

Das Modell und die Seriennummer

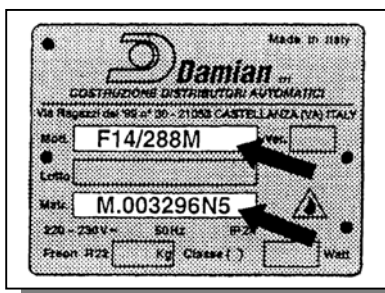

3°

The item number

Die Nummer des Teils

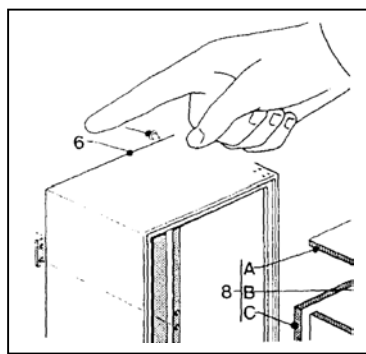

5°

For the painted parts, marked with "***" specify the colour

*Bei lackierten Teilen, die mit "***" gekennzeichnet sind, die Farbe angeben*

Col.	DESCRIPTION
2	Tornillo autorroscante TC - 3.9 x 9.5
3	*** Rejilla trasera armario
5	Distanciador para armario
3	Tornillo TPSCE 6 x 20
2	Tapa cubreagujero de plástico
1	*** Armazón armario
1	Pie de apoyo para armario
1	Placa de soporte para armario (SET)
1	Tornillo autorroscante TC - 2.9 x 6.5
7	Lengüeta desmontable para armario
4	Aislante para armario
2	Inserto para achafalado posterior
9	In...
5	De...

EX.	EB7/4/25C-R	Table A1	POS. 13	6150012 Cabinet frame	RAL 9005	N° 2
ES.	M. 003296N8	Taf. A1		6150012 Rahmen Schrank		

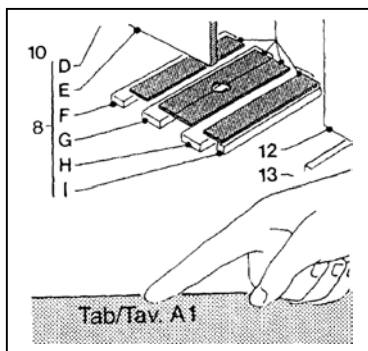

CODICE	Col.	DESCRIZIONE
0 03 802		Tornillo autorroscante TC - 3.9 x 9.5
2 50 013	**	Rejilla trasera armario
2 50 025		Distanciador para armario
0 03 443		Tornillo TPSCE 6 x 20
2 50 022		Tapa cubreagujero de plástico
2 50 001	**	Armazón armario
0 01 204		Pie de apoyo para armario
0 01 204		Placa de soporte para armario (SET)
0 03 802		Tornillo autorroscante TC - 2.9 x 6.5
2 50 022		Lengüeta desmontable para armario
0 01 204		Aislante para armario
2 50 022		Inserto para achafalado posterior
2 50 022		In...
2 50 022		De...

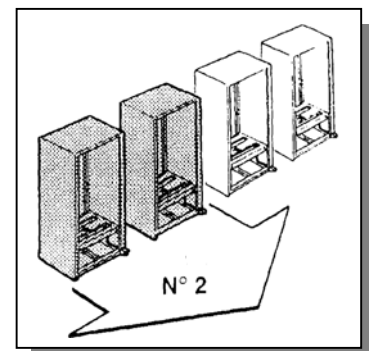

2°

The table number

Die Tafelnummer

4°

The code number and the description (abbreviated too)

Die Code-Nummer und die Beschreibung (auch abgekürzt)

6°

The quantity requested (see Note 1)

Die gewünschte Qualität (Siehe Hinweis 1)

Note 1: Bolts and screw minimum supply :
N° 20 parts

Nota 1: Mindest Bestellung für schraube:
Nr. 20 stück

UNIT INDEX

GRUPPENVERZEICHNISS

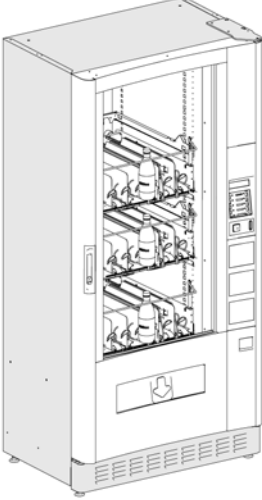
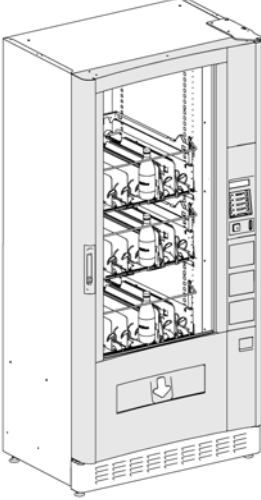
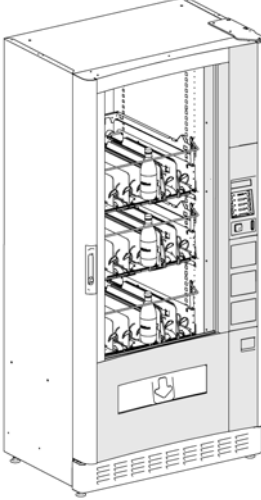
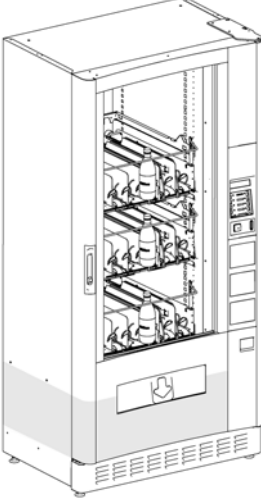
<p>CABINET UNIT GEHÄUSEEINHEIT</p>	<p>DOOR UNIT TÜREINHEIT</p>	<p>COIN BOX AND SLIDES MÜNZGERÄT UND RUTSCHEN</p>	<p>COOLING UNIT KÜHLUNGSEINHEIT</p>
<p>MOD LXS9</p>  <p>Tab./Taf. A1</p>	<p>MOD LXS9</p>  <p>Tab./Taf. B1</p>	<p>MOD LXS9</p>  <p>Tab./Taf. C1</p>	<p>MOD LXS9</p>  <p>Tab./Taf. D1</p>

UNIT INDEX

GRUPPENVERZEICHNISS

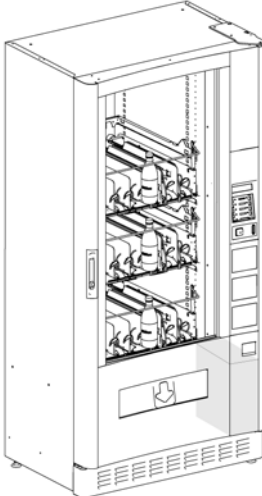
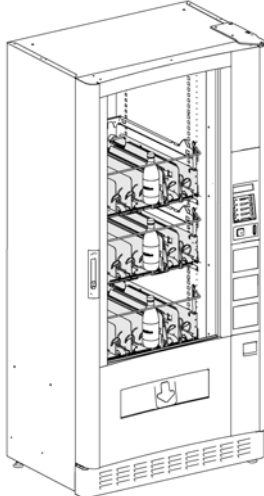
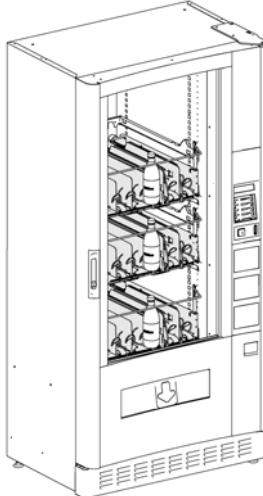
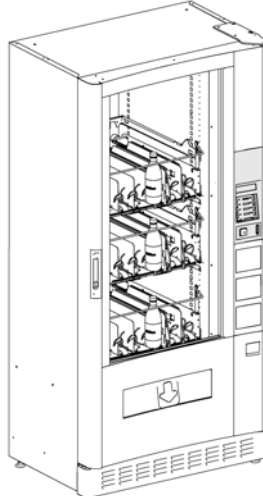
<p>ELECTRICAL BOX ELEKTROBOXEINHEIT</p>	<p>DRAWER UNIT SCHUBLADENEINHEIT</p>	<p>SPIRAL UNIT SPIRALENEINHEIT</p>	<p>ELECTRONIC CARDS STEUERPLATINEN</p>
<p>MOD LXS9</p>  <p>Tab./Taf. E1</p>	<p>MOD LXS9</p>  <p>Tab./Taf. F1</p>	<p>MOD LXS9</p>  <p>Tab./Taf. G1</p>	<p>MOD LXS9</p>  <p>Tab./Taf. H1</p>

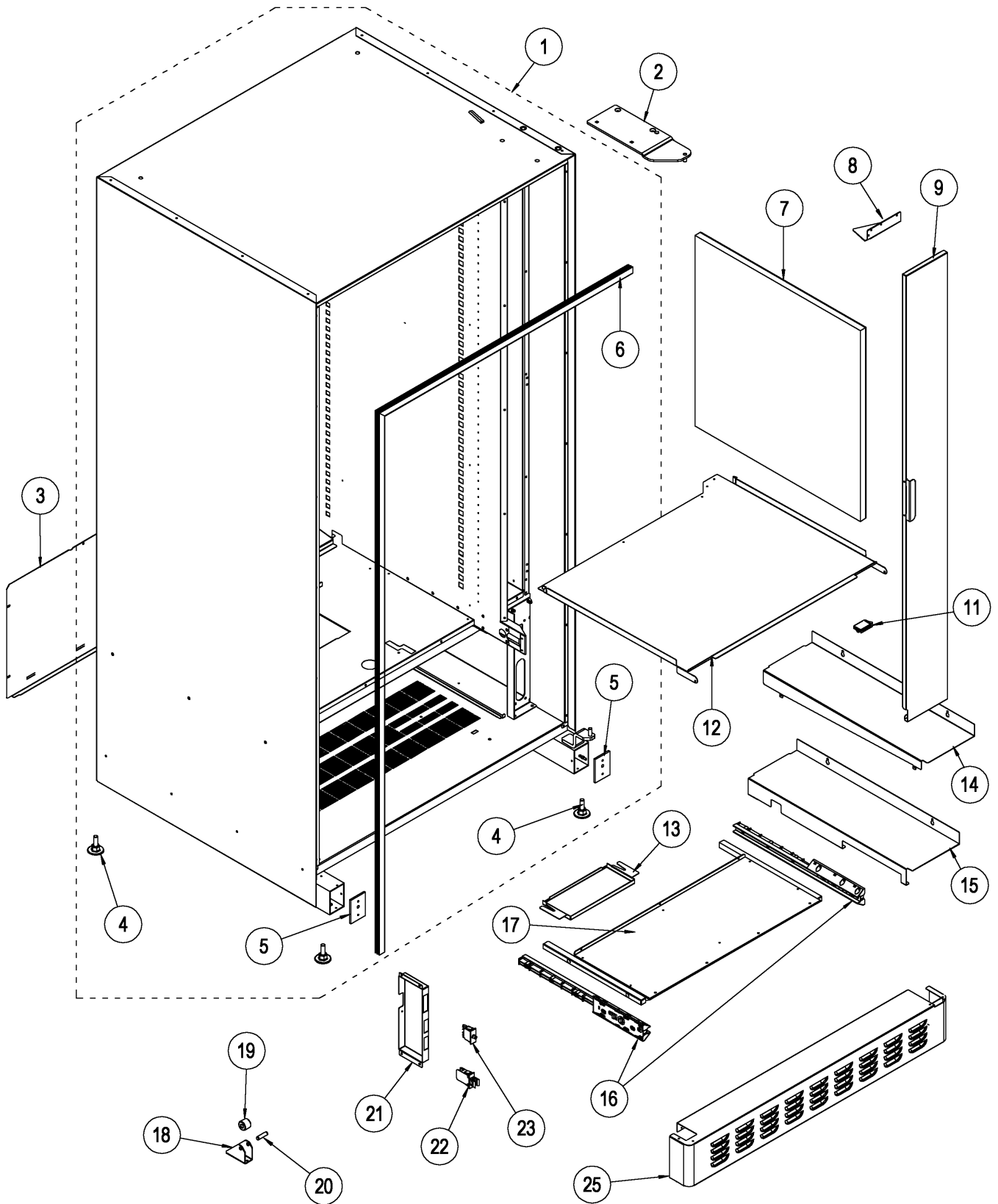

Pos.			Cabinet Unit	Gehäuseeinheit
	Code Codice	Farbe Col.	Description	Beschreibung
1	601 50 0004	**	LXS9 Cabinet unit with interior	Gehäuse mit Innenbestückung LXS9
2	601 50 0008-V		LXS9 Door upper pintle	Türangel oben LXS9
3	601 50 0007		Rear LXS9 grid	Lüftungsgitter hinten LXS9
4	00 01 4001		Cabinet foot	Gehäusefuß
5	00 01 5074C		Cap 70x50 for basement LXS9 complete	Deckel Bodenstützen LXS9 (70x50)
6	601 50 0022		LXS9 Magnetic gasket to 'L'	Magnet-Dichtung Tür L-Förmig LXS9
7	601 57 0012		Aluminized polyurethane insulation 568x568x20	Isolierplatte Alu 568x568x20 LXS9
8	601 56 0016		Stop for door compartment escort LXS9	Winkel für Türe Vorratsraum LXS9
9	601 56 0110		LXS9 Compartment escort door complete	Türe Vorratsraum Kpl. LXS9
11	00 01 7050		Magnetic lock for cover EP8-LXS9	Magnetblock für Türe Vorratsraum LXS9-EP8
12	601 40 0039		Separator air flow cabinet LXS9	Trennboden (für Umluft) LXS9
13	601 50 0043		Motor sliding panel cover LXS9 complete	Schutzblech Schlitten-Motor LXS9
14	601 56 0013		Upper shelf tray stock LXS9	Ablageblech oben Vorratsraum LXS9
15	601 56 0012		Lower shelf tray stock LXS9	Ablageblech unten Vorratsraum LXS9
16	601 50 0042		Guide sliding panel-support FTCA LXS9	Führung Schutz-Schlitten FTCA LXS9
17	601 50 0130		Sliding panel complete LXS9	Schutz-Schlitten Kpl. LXS9
18	601 50 0040		Bracket for wheel LXS9 door	Führung Rolle (Türe) LXS9
19	00 04 1003		Nylon wheel LXS9 door support	Rolle Türe unten LXS9
20	00 04 0059		8x32 pin	Bolzen 8x32 (Rolle/Führung)
21	601 50 0057		Cover switches LXS9 cabinet	Abdeckung Schalter LXS9
22	00 02 7006		Door safety switch	Türkontaktschalter
23	00 02 7032		LXS9 Switch button (ser.701)	Türkontaktschalter einpolig LXS9 (ser.701)
25	601 50 0009C	**	LXS9 Complete Cabinet skirting	Fussblende LXS9

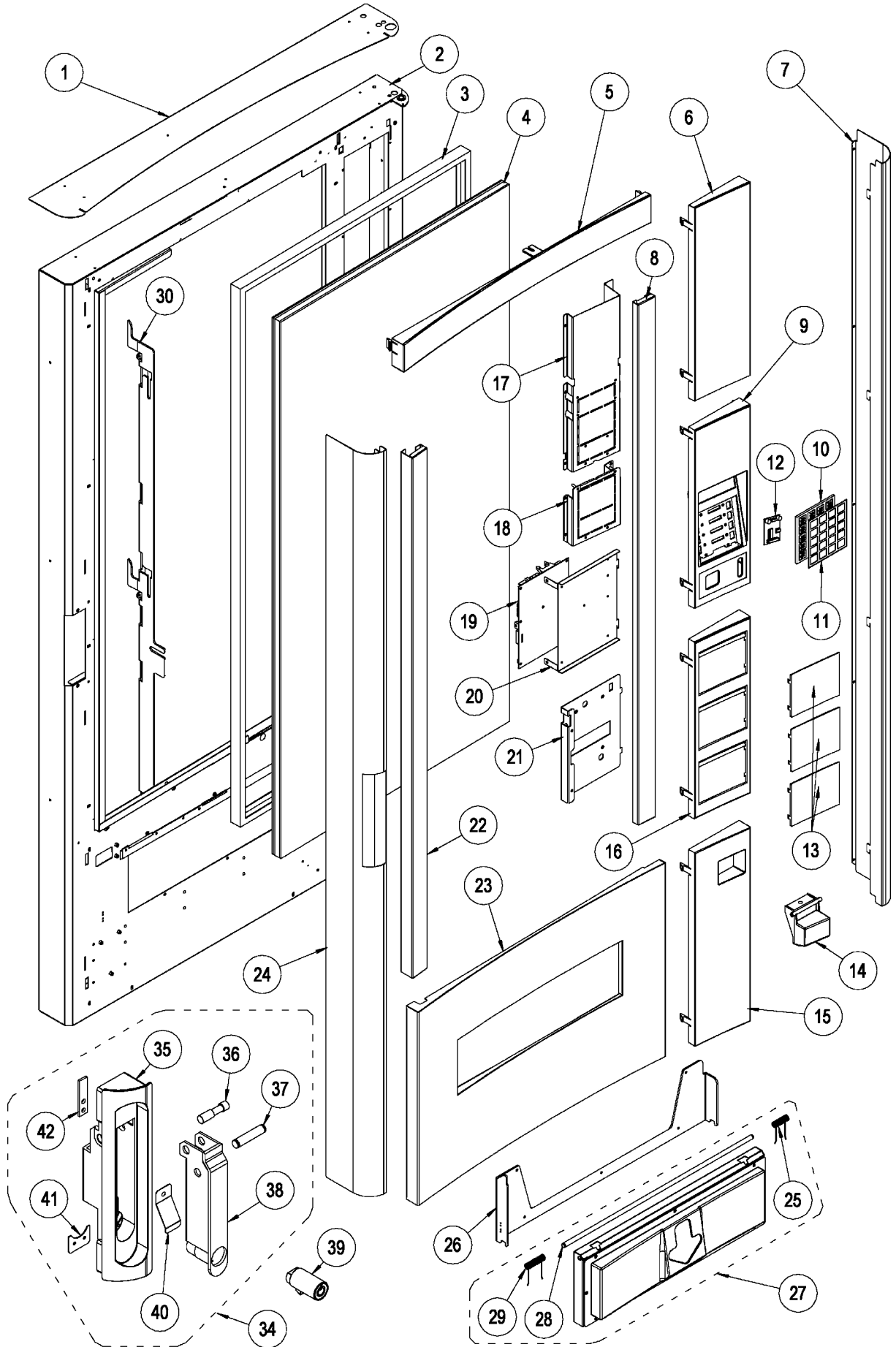

Pos.	Code		Farbe Col.	Door Unit	Türeinheit
	Codice			Description	Beschreibung
1	601 10	0017-V	**	LXS9 Aesthetic upper door closing	Blende Türkopf oben LXS9
2	601 10	0003-G		LXS9 Door frame complete	Türe aussen Kpl. LXS9
3	601 10	1008		Complete LXS9 showcase seal	Dichtung Glasscheibe Kpl. LXS9
4	601 10	1021		LXS9-Pro double glazed glass-case	Glasscheibe "doppelt" 2-Grad LXS9
5	601 10	0024-V	**	LXS9 Upper door protection aesthetic	Blende obere Front Türe LXS9
6	RH0020042042-V		**	Aesthetic module band payment system LXS9	Blende ob. Rechts f. Modul-Zahlsystem LXS9
7	601 10	0013-V	**	Right lateral vertical curve aesthetic LXS9	Blende rechte Seite gekurvt LXS9
8	601 10	0023-V	**	LXS9 Profile aesthetic vertical flat right for led	Blende re. Flachprofil LED LXS9
9	RH0020042043-V		**	Aesthetic module band for display LXS9	Blende Display LXS9
10	00 06	8008	**	K-Sens Keyboard 20 keys for LXS9	Tastaturplatine K-Sens 20 Tasten LXS9
11	00 01	8060	**	Adhesive serigraphy for K-Sens Keyb. 20 keys	Tastaturfeld Kapaz. 20er klebend LXS9
12	00 06	7057		Interface card for K-Sens 20 keys	Interfaceplatine für Tastatur K-Sens LXS9
13	RH0020042079			LXS9 Door instructions glass	Domino Fenster LXS9
14	RH0020042056-V		**	LXS9 Coin retur flap	Münzrückgabe LXS9
15	RH0020042045-V		**	Aesthetic module band coin return LXS9	Blende Münzrückgabe LXS9
16	RH0020042044-V		**	Aesthetic module band instructions glass LXS9	Blende Domino Fenster LXS9
17	RH0020042106			Removable LXS9 door plate type 'A'	Halterung -A- hinter ob.Front re. LXS9
18	RH0020042149			Support reader banknotes LXS9	Halterung Bonknotenleser LXS9
19	00 06	1040		CL1 CPU Flash electronic card for LXS9	CPU Flash CL1 LXS9
20	601 15	0005		Support CLP1 CPU Flash electronic card LXS9	Halterung CPU CL1 LXS9
21	RH0020042063			LXS9 Coin box support	Halterung Münzgerät LXS9
22	601 10	0022-V	**	LXS9 Profile aesthetic vertical flat left for led	Blende li. Flachprofil LED LXS9
23	601 10	0028	**	LXS9 Lower door protection aesthetic	Blende Klappenumrahmung LXS9
24	601 10	0014-V	**	Left lateral vertical curve aesthetic LXS9	Blende linke Seite gekurvt LXS9
25	61 10	3044		Spring for R.2 EB product flap	Feder Klappe / EB R.2
26	601 10	0011-V		Plate of coupling to electromagnet 'Push' LXS9	Aufhängung für Klappe "Push" LXS9
27	601 10	0009	**	LXS9 Product extraction door complete 'Push'	Klappe "Push" Kpl. LXS9
28	601 10	0035		Rot D.8 for product extraction door LXS9	Stange "Push" LXS9
29	601 10	0044		Spring for LXS9 product flap	Feder Klappe / LXS9
30	601 13	0006		LXS9 Handle carillon	Schließgestänge Tür LXS9
34A	601 13	0015	**	LXS9 Complete door handle Standard/7000	Schloß Kpl. Rundform LXS9 (Standard/7000)
34B	601 13	0016	**	LXS9 Complete door handle Vend Lock (Rielda)	Schloß Kpl. Vend-Lock LXS9 (Rielda)
35	601 13	0007-V	**	Frame for LXS9 handle	Rahmen Griff LXS9
36	00 04	0085		LXS9 Handle pin 8 x 34	Bolzen 8x34 Griff LXS9
37	00 04	0084		LXS9 Handle pin 8 x 36,5	Bolzen 8x36,5 Griff LXS9
38A	601 13	0009-V	**	LXS9 External handle frame (hole ø9,5)	Griff ø9,5-Loch Std. LXS9
38B	601 13	0012-V	**	LXS9 External handle frame (hole ø7,5) V. Lock	Griff ø7,5-Loch Vend-Lock LXS9
39A	13 13	0001		Round cylinder for lock standard	Zylinder für schloß rund
39B	12 13	0001		Round cylinder for lock mod.7000	Zylinder für schloß 7er SST
39C	00 01	7055		Round cylinder for lock program. Rielda 4014	Zylinder rund progr. Rielda 4014
40	601 13	0010		LXS9 door handle spring	Druckblech für Griff LXS9
41	601 13	0011		Thickness for lock handle LXS9	Distanzstück für Zylinder LXS9
42	75 13	0008		Stop for Sh-EB handle	Blockierplatte für Griff LXS9/Sh-EB

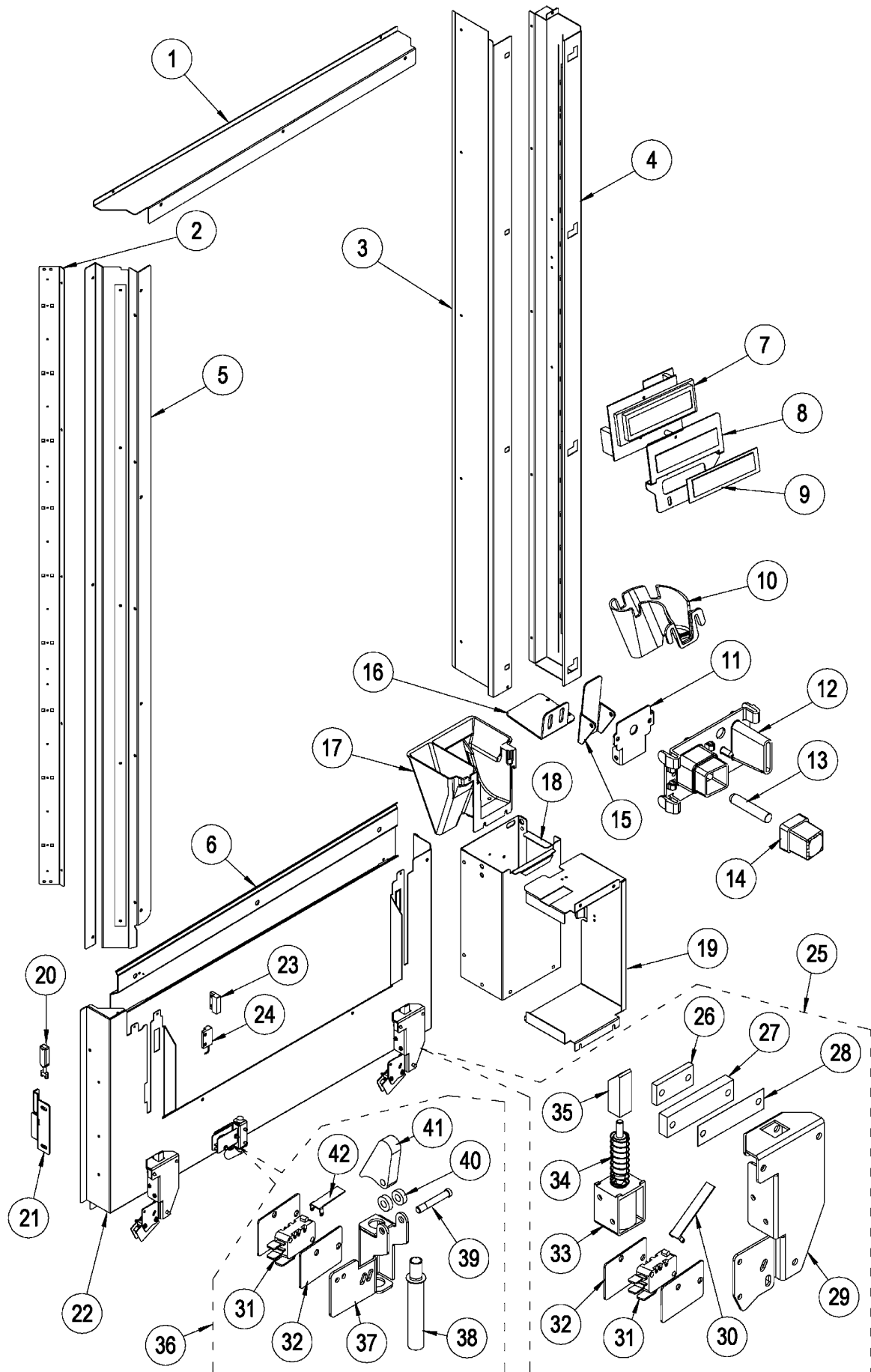

Pos.	Code Codice	Farbe Col.	Coin box and slides	Münzgerät und Rutschen
			Description	Beschreibung
1	601 10 1013		LXS9 Upper horizontal glass stopper (Led)	Glashalterung oben LXS9
2	601 10 1041		LXS9 Left lamp led support complet (3x6 Led)	Halterung LED Beleucht. li. 3x6kpl. LXS9
3	601 10 1020-V		LXS9 Right lamp led support	Halterung LED Beleucht. re. 3x6kpl. LXS9
4	601 10 1040		LXS9 Right lamp led cover complet (3x6 Led)	Abdeckung LED Beleucht. re. Kpl. LXS9
5	601 10 1024		LXS9 Left glass stopper (led)	Glashalterung links LXS9
6	601 10 1012		LXS9 Lower horizontal glass stopper	Glashalterung unten LXS9
7	00 06 1041		Display card for LXS9	Displayplatine+Interface LXS9
8	601 15 0002		LXS9 display card support	Halterung Displayplatine.LXS9
9	RH0020030271		LXS9 display transparent glass	Displayscheibe LXS9
10	00 01 8030		Coin entry slide	Münzrutsche
11	RH0020042064		LXS9 Support for change return square	Halterung Münzrutsche /Luce X2/LXS9
12	RH0020042083		LXS9 Coin entry support	Halterung Münzeinwurf /LuceX2/LXS9
13	00 04 0082		EPL8M-LXS9 Coin return pin	Stift Rückgabeknopf EP8M/LXS9
14	RH0020042062-V	**	LXS9 Coin return button	Rückgabeknopf /auch Luce X2/LXS9
15	RH0020042057		Lower square for LXS9 coin rejection	Stützblech für Halt. Münzrutsche/LX2/LXS9
16	RH0020042052		LXS9 Coin return lever	Hebel Rückgeld /Luce X2/LXS9
17	RH0020042014		LXS9 Change return box	Münzrückgabe / Luce X2/LXS9
18	601 12 0014		LXS9 Coin box	Behälter Kasse LXS9
19	601 12 0013		LXS9 Coin box support	Halterung Behälter Kasse LXS9
20	00 02 7007		Safety switch key	Türkontaktschlüssel
21	601 10 0043		LXS9 Safety switch bracket	Winkel Türkontakt LXS9
22	601 10 0027		LXS9 lower door closing	Abdeckung unten LXS9
23	00 01 7065		LXS9 Magnet for sensor Reed M4	Magnet für "Reed Sensor-Push" LXS9
24	00 01 7066		Sensor Reed MK04U-1A71 for LXS9	Sensor "Reed Push" LXS9 (MK04U-1A71)
25	601 10 0036		Complete magnet group for block 'Push' LXS9	Klappen-Blockier System Kpl. LXS9
26	601 10 0049		Short skater for magnet pivot LXS9	Gleitschuh kurz für Magnetstift LXS9
27	601 10 0050		Long skater for magnet pivot LXS9	Gleitschuh lang für Magnetstift LXS9
28	601 10 0048		Thin layer for compensation magnet LXS9	Ausgleichsblättchen für Magneten LXS9
29	601 10 0030		Electromagnet block 'Push' support LXS9	Halterung Magnetblock "Push" LXS9
30	00 02 7015		Lever for microswitch R=38 without wheel	Bügel Mikroschalter R=38 o. Rolle (161A)
31	00 02 7003		Microswitch CROUZET 83161.3	Mikroschalter CROUZET 83161.3
32	00 01 2002		Insulated plate for micro- switch	Isol. platte für mikroschalter
33	00 02 6022		Electromagnet PR1S-024D-P79 (LXS9)	Elektromagnet "Push" LXS9 (PR1S-024D-P79)
34	601 10 0034		Spring for pivot of electromagnet 'Push' LXS9	Feder für Magnetbolzen LXS9
35	601 10 0039-V		Head for pivot of electromagnet 'Push' LXS9	Kopfteil für Magnetbolzen LXS9
36	601 10 0046		Complete support piston of slowing-down LXS9	Bolzen-Bremse Kpl. LXS9
37	601 10 0031		Support for piston of slowing-down LXS9	Halterung Bolzen LXS9
38	601 10 0041		Piston of slowing-down BLM	Bolzen für Bremse BLM
39	00 04 0041		Stainless pin M5x27	Inox zapfen M5x27
40	00 04 0081		PVC spacer h.3 D.4,5 x 9,5	Distanzring 4,5x9,5 PVC
41	601 10 0038		Lever for piston of slowing-down LXS9	Hebel des Bolzen LXS9
42	00 02 7016		Lever for microswitch R=21,7 without wheel	Bügel Mikro R=21,7 o. Rolle (161A)

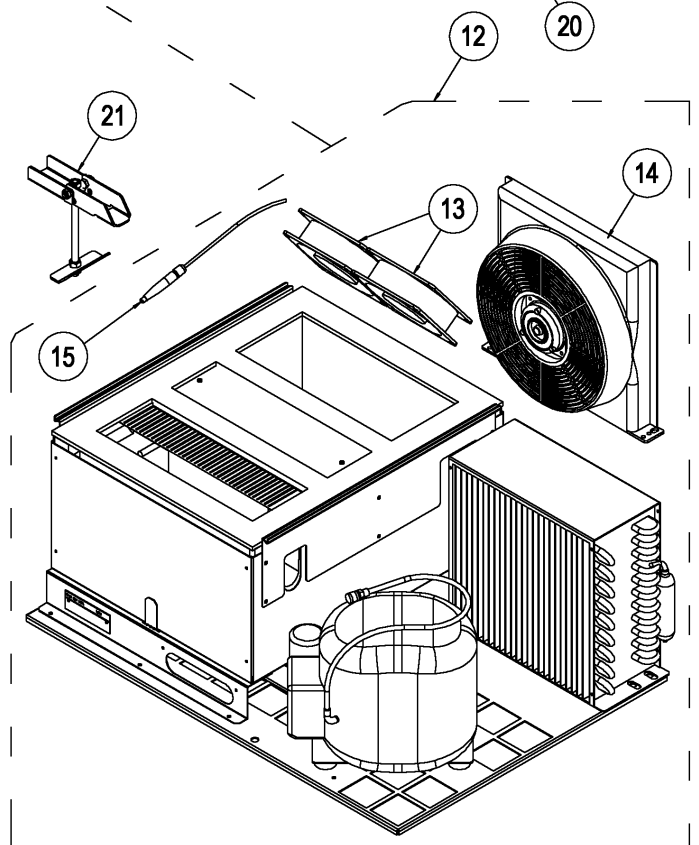
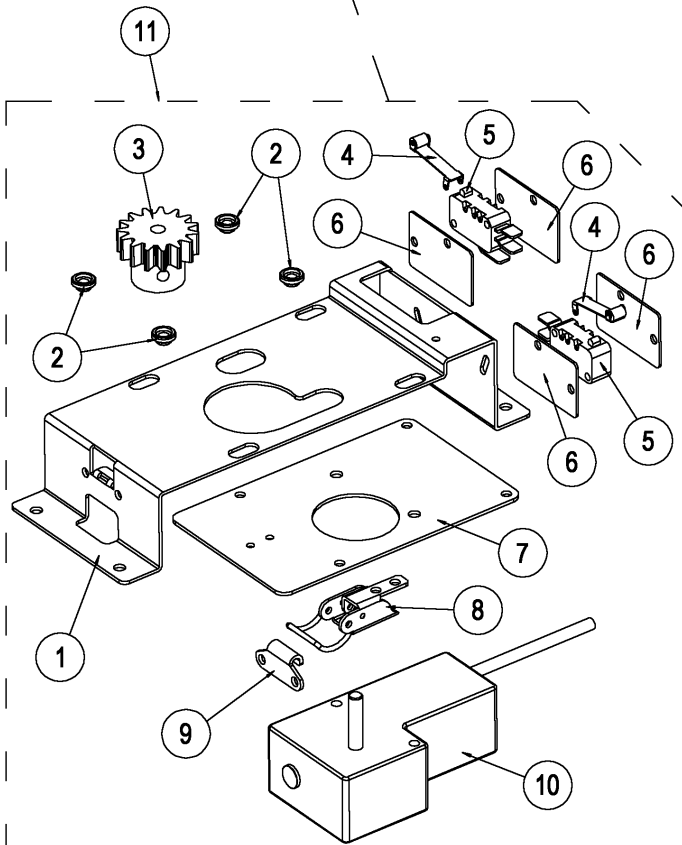
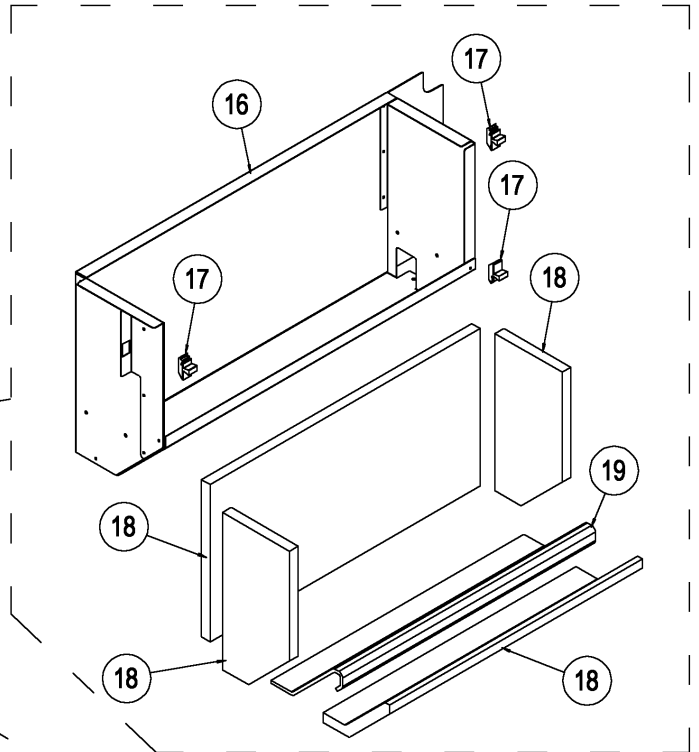
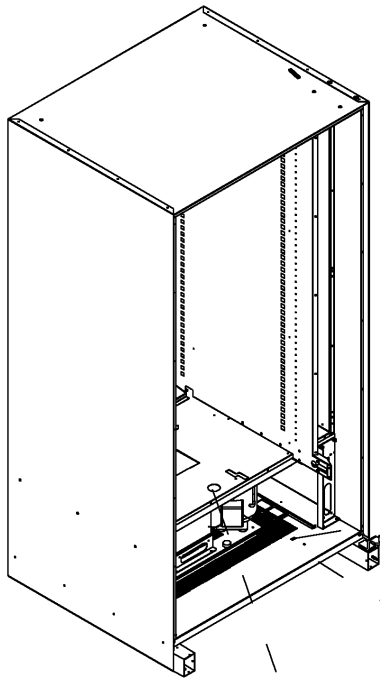

Pos.	Code		Cooling unit	Kühlungseinheit
	Codice	Farbe Col.		
1	601 50 0038		LXS9 Anti-theft motor support plate	Halter-Platte Schlittenmotor LXS9
2	66 10 0008		Door lever spacer EP8	Produkthebelabstandshalter EP8
3	601 50 0036		LXS9 Anti-theft sliding panel gearwheel	Zahnrad Schlitten LXS9
4	00 02 7011		Micro lever 24mm with wheel	Bügel Mikro 24mm mit Rolle (161.E)
5	00 02 7003		Microswitch CROUZET 83161.3	Mikroschalter CROUZET 83161.3
6	00 01 2002		Insulated plate for micro- switch	Isol. platte für mikroschalter
7	601 50 0032		Sliding anti-theft motor support LXS9	Halterung Schlitten-Motor LXS9
8	00 01 7062		Closure at lever TL 17-201-07	Kippverschl. Schlitten-Motor (TL17-202-07)
9	00 01 7063		Couple for closure TL 17-201-07	Hacken für Kippverschluss (TL 17-201-07)
10	601 51 0019		Motor 24Vdc 287 Rpm anti-theft LXS9	Motor 24V/DC Schlitten LXS9 (287 Rpm)
11	601 50 0132		Unit anti-theft motor LXS9 complete	Schlitten-Motor Kpl. LXS9
12	601 40 0001		LXS9 Cooling unit Super	Kühlung Einschub LXS9 Kpl.
13	601 40 0005		Fan for cooling unit evaporator LXS9 (with cable)	Lüfter Verdampfer LXS9 (mit Kabel)
14	601 40 0015		Fan for cooling unit compressor LXS9	Lüfter Kompressor LXS9
15	00 06 9030		Blu temperature probe for cooling unit	Temperatursonde "blau"
16	601 50 0005		LXS9 Front panel (Tray)	Produktwanne LXS9
17	00 01 7060		Closure panel to push A3-30-519-12	Produktwannenklipp (A3-30-519-12)
18	63 50 0003		Front panel insulation device XTS5/EM8S	Isolierplatte EM8S/ XTS5
19	00 01 2017		Drilled insulation device Sp.6x1400 (per meter)	Lochleiste 6x1400mm (lfm) LXS9
20	601 50 0006		Complete front panel LXS9 (Tray)	Produktwanne Kpl. LXS9
21	601 40 0126		Complete hook for cooling unit LXS9	Aufhängung für Kühlung Kpl. LXS9

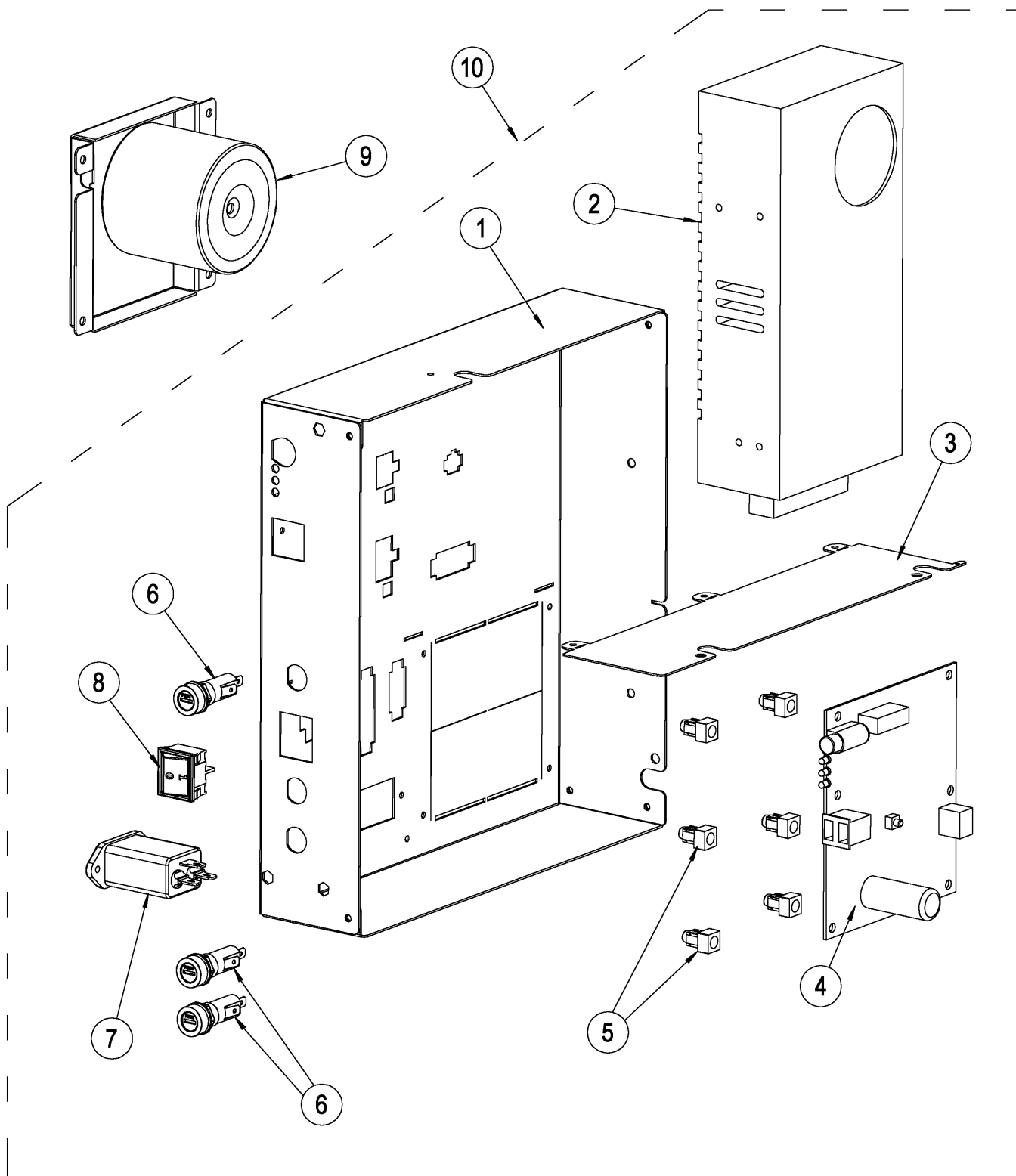

Pos.			Electrical box	Elektroboxeinheit
	Code Codice	Farbe Col.	Description	Beschreibung
1	601 51 0004		Electric box frame LXS9	Gehäuse Elektrobox LXS9
2	601 51 0005		Switching power pack 28Vdc for LXS9	Netzteil 28Vdc LXS9
3	601 51 0003		LXS9 Electrical box separator	Trennwand Elektrobox LXS9
4	00 06 5009		CLP1 Power 1 electronic card for LXS9	Powerplatine CLP1 LXS9
5	00 04 0092		Spacer (rawplug) h.6,4	Sockel Abstandshalter h.6,4 (EG-4-01)
6	00 02 9006		P2300 EP8 ATM-T Single Fuse Holder	Sicherungshalter P2300/EP8
7	00 02 0073		Panel pin with filter 10A	Stecker mit 10A Filter für Paneel
8	00 02 7030		XTS5 Electrical box switch	Schalter (ein/aus) XTS-LXS9
9	601 51 0030		Kit option for Executive LXS9	KIT Exekutive "optional" LXS9
10	601 51 0010		LXS9 Electrical box complete	Elektrobox Kpl. LXS9

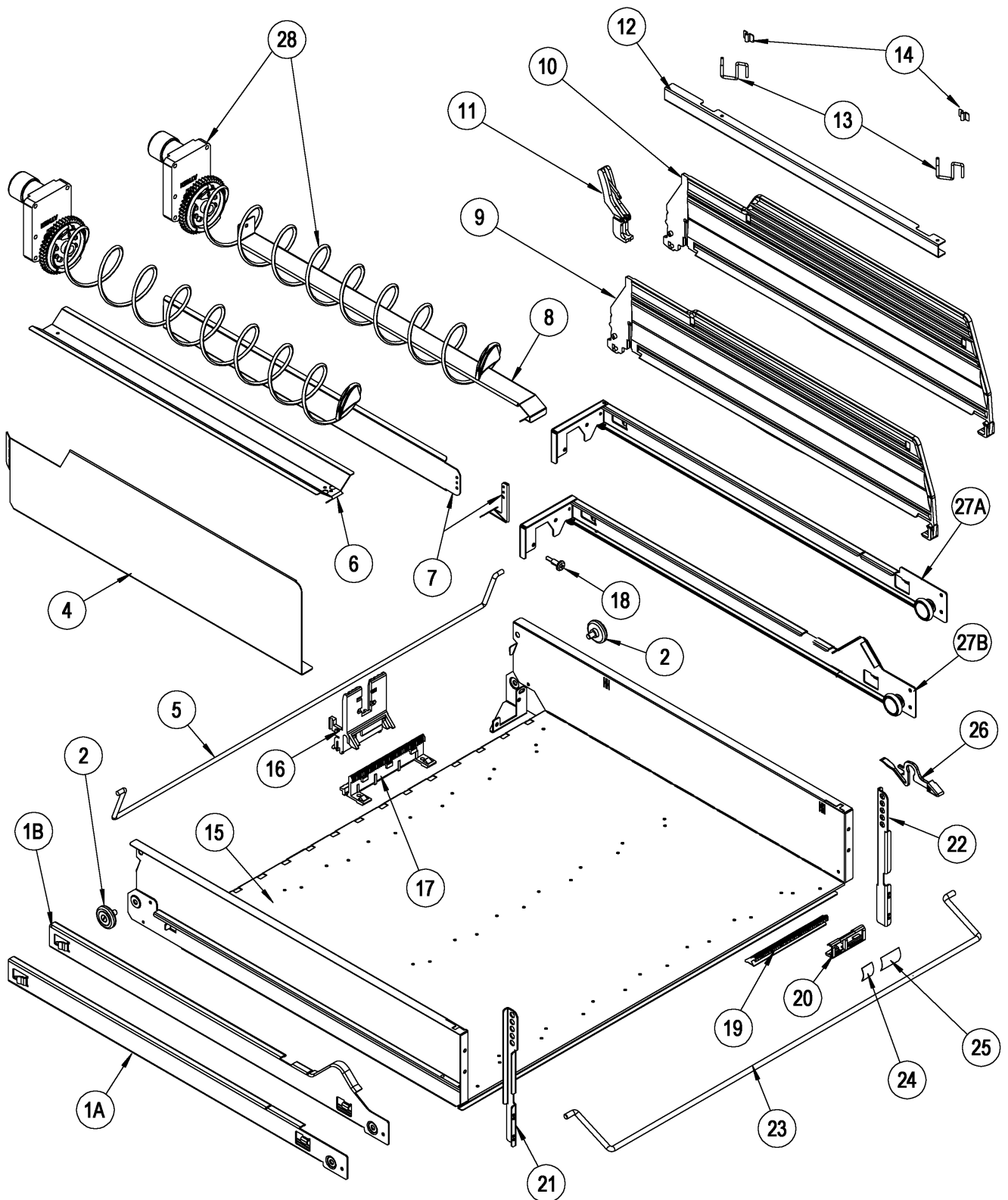

Pos.	Code	Farbe Col.	Drawer Unit	Schubladeinheit
	Codice		Description	Beschreibung
1A	61 30 0003C		Drawer fixed left-hand guide with wheel	Führung linke Schublade Gera. Kpl.
1B	61 30 1003C		Drawer reclining left-hand guide with wheel	Führung linke Schublade Gera. Kpl.
2	61 30 2015		EB/EP8/LS9 Drawer sliding wheel	Laufrolle EB/EP8/LXS9
4	601 30 0024-V		LXS9 Metal product separator	Trennwand Metall LXS9
5	601 30 0018		LXS9 support cable drawer rod	Bügel Kabelhalterung LXS9
6	601 30 0008-V		LXS9 Product conveyor spiral	V-Schiene LXS9
7	601 30 1026		LXS9 spiral separator complete	Trennwand 1/2 Spirale Kpl. LXS9
8	601 30 0017		LXS9 Product support bridge stainless steel	Laufschiene Inox LXS9
9	601 30 1019		LXS9 Plastic product separator (Low)	Trennwand Plastik (Niedrig) LXS9
10	601 30 1024		LXS9 Plastic product separator (high)	Trennwand Plastik (hoch) LXS9
11	601 30 1020		Lever for LXS9 plastic product separator	Kipphebel Trennwand Plastik LXS9
12	61 30 0049-V		Products spacer	Abstandsregler Produkte
13	61 30 0052		Hinge for products spacer	Abstands Scharnier
14	61 30 0051		Omega square for products spacer	Abstands Sicherung Omega
15	601 30 0013		LXS9 Drawer (sheet metal with guides)	Schublade mit Führung "nackt" LXS9
16	601 30 0035		Support single-motor for drawer LXS9	Motor Halter LXS9
17	601 30 0036		LXS9 Rack support for drawer motor	Zahnraster für Mototrhalter LXS9
18	00 04 0065		EB connector spacer 12,5 x 8	Distanzstift für Führung LXS9-EB 12,5x8
19	601 30 0037		LXS9 Rack support for price holder	Zahnraster für Preishalter LXS9
20	601 30 0016		LXS9 Price holder drawer	Preishalter Schublade LXS9
21A	601 30 0061		Left high support for bottle drop stopper LXS9	Halter linke Flasch.Bügel hoch Std. LXS9
21B	601 30 0065-V		Left low support for bottle drop stopper LXS9	Halter linke Flasch. Bügel niedrig LXS9
22A	601 30 0062		Right high support for bottle drop stopper LXS9	Halter rechte Fl.-Bügel hoch Std. LXS9
22B	601 30 0066-V		Right low support for bottle drop stopper LXS9	Halter rechte Fl.-Bügel niedrig LXS9
23A	601 30 0063		Mobile rod for high bottle drop stopper LXS9	Bügel Flaschen hoch Std. LXS9
23B	601 30 0067		Mobile rod for low bottle drop stopper LXS9	Bügel Flaschen niedrig LXS9
24	601 32 0011		LXS9 Positions sheet	Positionsschilder LXS9
25	601 32 0021		LXS9 Prices sheet	Preisschilder LXS9
26	601 30 0041		LXS9 Drawers stop bracket	Hebel Klammer Schubl. LXS9
27A	601 30 0002C		LXS9 Drawer fixed right-hand guide with wheel	Führung rechte Schubl. Gera. Kpl. LXS9
27B	601 30 1002C		LXS9 Drawer reclining right-hand guide with w.	Führung rechte Schubl. Neig. Kpl. LXS9
28	V t s		See Spiral Unit (Table G1)	Siehe Spiraleinheit (Tabelle G1)

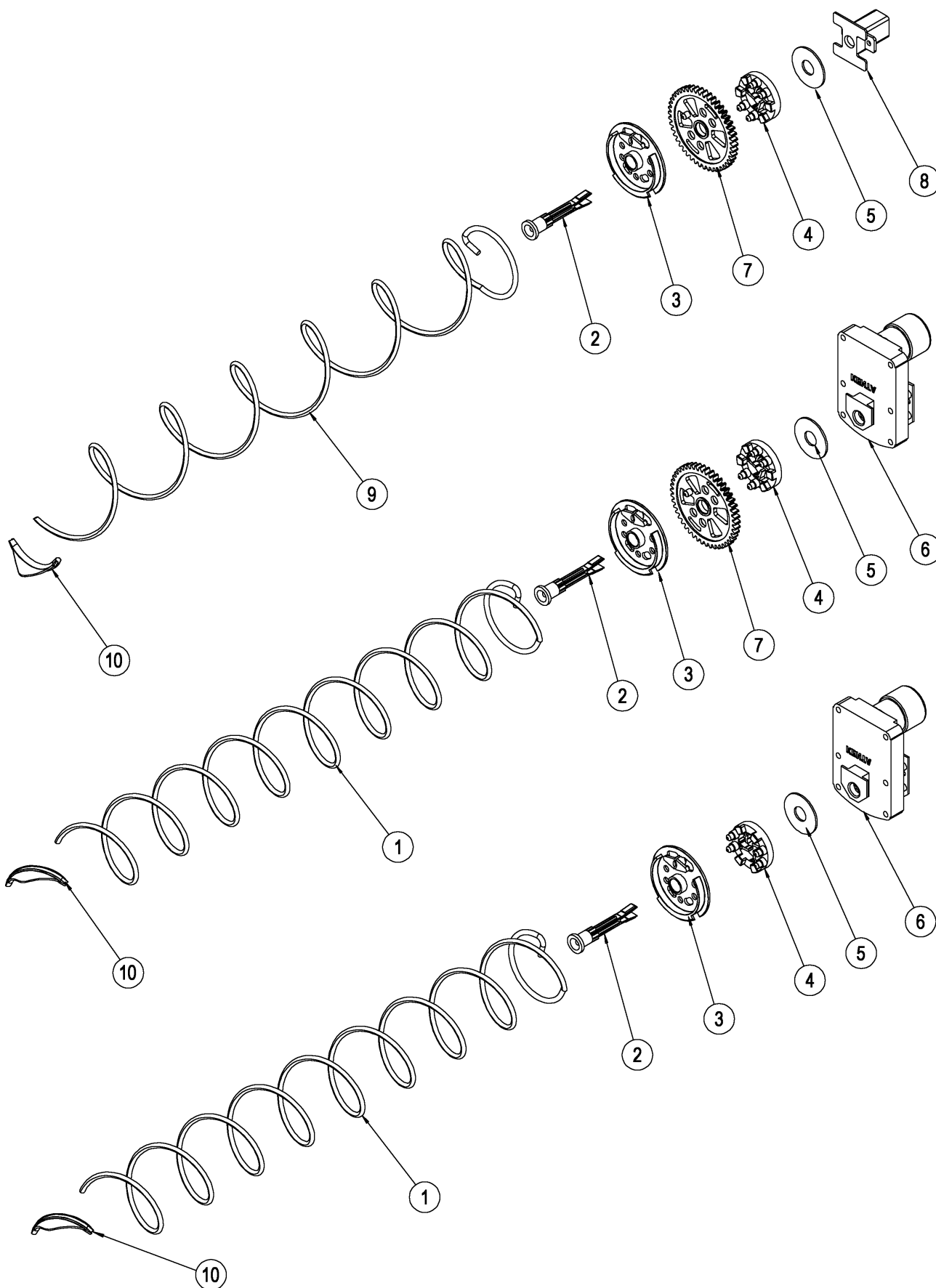

Pos.			Spiral Unit	Spiraleneinheit
	Code Codice	Farbe Col.	Description	Beschreibung
1A	61 31 1024-V		Right spiral D.65 thread 24 (20 products)	Rechte Spirale D.65 Steigung 24 (20 Produkte)
1B	61 31 1032-V		Right spiral D.65 thread 32 (15 products)	Rechte Spirale D.65 Steigung 32 (15 Produkte)
1C	61 31 1045-V		Right spiral D.65 thread 45 (10 products)	Rechte Spirale D.65 Steigung 45 (10 Produkte)
1D	61 31 1060-V		Right spiral D.65 thread 60 (8 products)	Rechte Spirale D.65 Steigung 60 (8 Produkte)
1E	61 31 1079-V		Right spiral D.65 thread 78,5 (6 products)	Rechte Spirale D.65 Steigung 78,5 (6 Produkte)
1F	61 31 1091		Right spiral D.65 thread 94 (5 products)	Rechte Spirale D.65 Steigung 94 (5 Produkte)
1G	61 31 1117		Right spiral D.65 thread 117 (4 products)	Rechte Spirale D.65 Steigung 117 (4 Produkte)
2	601 30 0029		LXS9 Spiral motor shaft	Klemmstift Spiralenmotor LXS9
3	601 30 0012		LXS9 Spiral attachment ring nut	Kupplung Spirale LXS9
4	601 30 0034		LXS9 friction for spiral attachment ring	Kupplunghalter "Stiftring" LXS9
5	00 03 2060		Nylon washer D. 12,7-35 thickness 1,5	U-Scheibe Mot." Nylon" 12,7-35 d.1,5 LXS9
6	61 30 1011		Spiral gearmotor	Spiralen-Motor 24V
7	601 30 0031		LXS9 Spiral toothed wheel	Zahnrad f. Spiralenmot. LXS9
8	601 30 0032		LS9 Bush for toothed wheel	Buchse für Getriebe spir. Ohne Motor LXS9
9A	61 31 2024-V		Left spiral D.65 thread 24 (20 products)	Linke Spirale D.65 Steigung 24 (20 Produkte)
9B	61 31 2032-V		Left spiral D.65 thread 32 (15 products)	Linke Spirale D.65 Steigung 32 (15 Produkte)
9C	61 31 2045-V		Left spiral D.65 thread 45 (10 products)	Linke Spirale D.65 Steigung 45 (10 Produkte)
9D	61 31 2060-V		Left spiral D.65 thread 60 (8 products)	Linke Spirale D.65 Steigung 60 (8 Produkte)
9E	61 31 2079-V		Left spiral D.65 thread 78,5 (6 products)	Linke Spirale D.65 Steigung 78,5 (6 produkte)
9F	61 31 2091		Left spiral D.65 thread 94 (5 products)	Linke Spirale D.65 Steigung 94 (5 produkte)
9G	61 31 2117		Left spiral D.65 thread 117 (4 products)	Linke Spirale D.65 Steigung 117 (4 produkte)
10	60 30 0043		Small spoon for spiral	Auswurf flippe LXS9

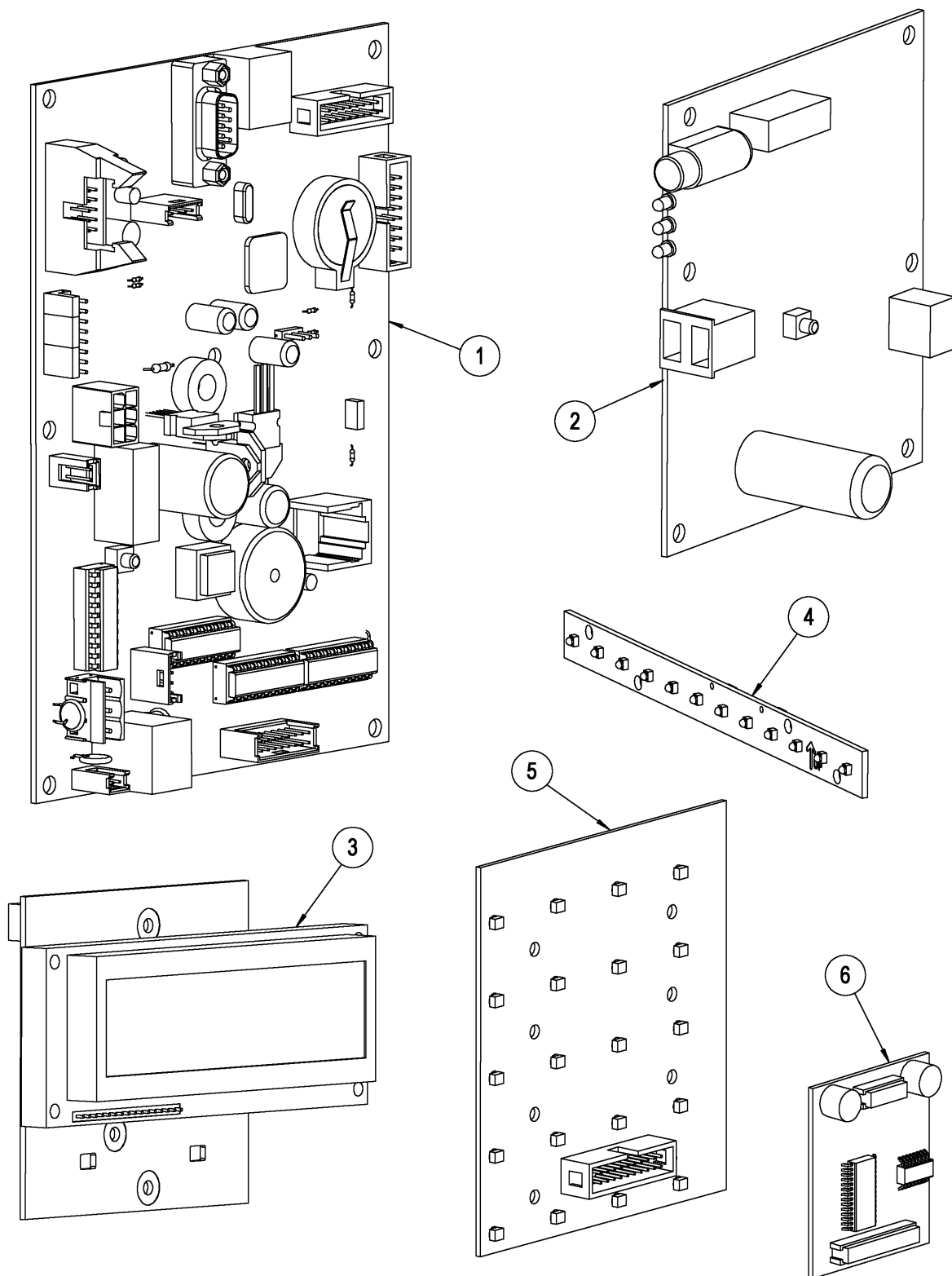

Pos.			Electronic cards	Steuerplatinen
	Code Codice	Farbe Col.	Description	Beschreibung
1	00 06 1040		CL1 CPU Flash electronic card for LXS9	CPU Flash CL1 LXS9
2	00 06 5009		CLP1 Power 1 electronic card for LXS9	Powerplatine CLP1 LXS9
3	00 06 1041		Display card for LXS9	Displayplatine+Interface LXS9
4	00 06 7041		LXS9 FTCA 2 barrier-card	FTCA-Platine Fallschutz LXS9
5	00 06 8008	**	K-Sens Keyboard 20 keys for LXS9	Tastaturplatine K-Sens 20 Tasten LXS9
6	00 06 7057		Interface card for K-Sens 20 keys	Interfaceplatine für Tastatur K-Sens LXS9

Riserva di modifica tecnica

Al fine di migliorare costantemente la qualità dei propri prodotti e di garantire un sempre maggiore livello di sicurezza e di protezione ambientale, la Damian S.r.l., si riserva di modificare senza preavviso le caratteristiche tecniche e costruttive dei propri prodotti.

La Damian S.r.l. si riserva di comunicare ai propri clienti a mezzo di bollettini di informazione, aggiornamenti dei manuali, comunicazioni od ogni altro mezzo di informazione che riterrà opportuno tutte le modificazioni che interessassero la sicurezza o protezione ambientale ed ogni altra informazione che comunque si riveli utile.

Reservation of technical modification

To improve the quality of the products and to guarantee a higher and higher safety and environmental protection level, Damian S.r.l. reserves the right to change the technical particulars and the constructive features of its own products without notice.

Damian S.r.l. reserves the right to inform its customers by information slips, handbook updating, communication or other proper means of information all the changes regarding safety and environmental protection and all other information which could be useful.

Reserve de modification technique

Au fin de améliorer continuellement la qualité de ses produits et de garantir toujours une meilleure sécurité et protection de l'ambiance la société Damian S.r.l. se réserve de modifier sans preavis les caractéristiques techniques et de construction de ses produits.

La Damian S.r.l. se réserve de communiquer à ses clients au moyen de bulletins d'information, mis à jour des manuels, communications ou d'autres systèmes d'information à son choix, toutes les modifications, qui intéressent la sécurité ou la protection de l'ambiance et d'autres informations utiles.

Reserva de modificacion tecnica

Para mejorar la calidad de sus productos y para garantizar un nivel siempre mayor de seguridad y de protección ambiental, la Damian S.r.l. se reserva modificar sin advertencia previa las características técnicas y de construcción de sus productos

La Damian S.r.l. se reserva comunicar a sus clientes por unos boletines informativos, por puestas al día de los manuales, comunicaciones, o todo otro medio de información que le parezca necesario todas las modificaciones que pudieran tener hacer con la seguridad o con la protección ambiental y toda otra información que parezca útil.

Rücklage von technischer Änderung

Um die Qualität der Produkte ständig zu verbessern und die höchsten Sicherheit und Umweltschutz zu gewährleisten, behält sich die Firma Damian S.r.l. das Recht vor die technischen und baulichen Merkmale der Produkte zu ändern.

Die Firma Damian S.r.l. behält sich das Recht vor, die Kunden über die Änderungen zu unterrichten, die Sicherheit und Umweltschutz betreffen, sie wird alle nützlichen Informationen durch Auskunftsberichte, Neubearbeitungen der Handbücher, Berichte oder durch andere zweckmäßigen Mittel mitteilen.

